

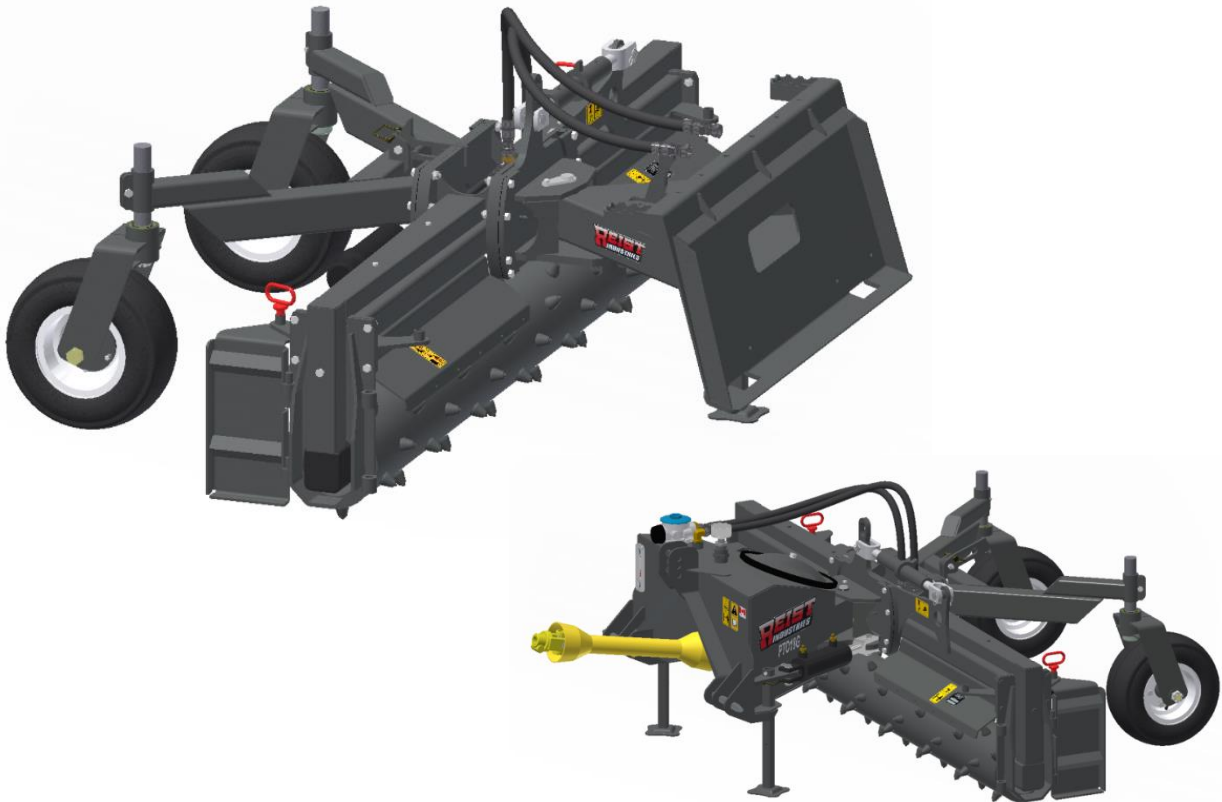

INNOVATION WORKING FOR YOU

RR84 & RR84PTO18G

Roto-Rake Operator and Parts Manual



REIST Industries Inc.
100 Union Street
Elmira, Ontario, Canada
N3B 3L7

Phone: 519-669-1501
Toll Free: 1-877-467-3478
www.reistindustries.com

Effective Serial Number X3841 to Y4400

Contents	
INTRODUCTION.....	2
PRODUCT CONFIGURATION	3
GENERAL SAFETY PRECAUTIONS	4
GENERAL SAFETY PRECAUTIONS	5
OPERATION AND TRANSPORTATION ON PUBLIC ROADS AND AREAS.....	6
SAFETY DECALS.....	7
MAINTENANCE	8
ADDITIONAL MAINTENANCE FOR THE PTO18G SERIES.....	8
PTO18G OIL FILTER MAINTENANCE	9
STANDARD SETUP INSTRUCTIONS.....	10
SKID-STEER HOOKUP INSTRUCTIONS	10
OPERATION OF ROTO-RAKE.....	10
PTO18G SETUP INSTRUCTIONS	11
PTO18G HOOKUP INSTRUCTIONS	11
OPERATION OF PTO ROTO-RAKE	11
GROUND SPEED:.....	11
STANDARD FEATURES ASSEMBLY	12
RR84 ROTO RAKE-ASSEMBLY.....	13
RR84 WHEEL ASSEMBLY	14
STANDARD 15 DEGREE SWIVEL FRAME ASSEMBLY	15
RR84 - 15 DEGREE BASE SWIVEL FRAME ASSEMBLY	16
OPTIONAL ON THE FLY HYDRAULIC VALVE BLOCK.....	17
OPTIONAL HYDRAULIC VALVE BLOCK DETAILS	18
OPTIONAL VALVE BLOCK WIRING HARNESSSES	19
OPTIONAL DIVERTOR VALVE	20
OPTIONAL DIVERTOR VALVE DETAILS & SCHEMATIC	21
WIRING HARNESSSES.....	22
RR84PTO18G - ASSEMBLY	23
PTO18G – EXPLODED VIEW	24
PTO18G – PARTS LIST.....	25
OPTIONAL SIDE CUTTERS - RRSCK	26
OPTIONAL PLOW ATTACHMENT ASSEMBLY	27
WARRANTY INFORMATION.....	28

Record your product information for future reference:

Model Number: _____

Serial Number: _____

In Service Date: _____

Sold By: _____

INTRODUCTION

Thank you for choosing the REIST RR84 / RR84PTO18G ROTO-RAKE.

We feel confident that this equipment will meet your expectations in workmanship, reliability and performance when used as designed. This manual is to assist you with the safe operation of the REIST ROTO-RAKE. It also has a parts list to help you when replacement parts are required. Any person who will be assembling, attaching, maintaining, or operating this product and the prime mover to which it is attached, are required to read and completely understand the information and instructions contained in this manual and that of the prime mover. Always obtain further assistance by contacting the dealer from which this product was purchased or by contacting REIST Industries at the telephone number or address below. Keep this manual available for reference whenever this product is being handled or used and we recommend that it is reviewed periodically and before seasonal use. Provide this manual to any new owners and/or operators and ensure they fully understand the safe operation of this equipment before it is placed in service.

Replacement copies of this manual are available for downloading at:
www.reistindustries.com

Innovation Working for You

REIST Industries Inc.

100 Union Street
Elmira, Ontario, Canada
N3B 3L7

Phone: 519-669-1501
Toll Free: 1-877-467-3478

The illustrations and information contained within this manual were current at the time of publication. Under our policy of continuous improvement, we reserve the right to change specifications and designs without prior notice. The illustrations do not necessarily show the standard version of product offered by REIST Industries.

PRODUCT CONFIGURATION

To ensure that the ROTO-RAKE is matched to the right prime mover, REIST ROTO-RAKE models are as follows:

ROTO-RAKE

Model	Working Width	GPM	Max PSI	Mount	Pounds	Kilograms
RR84	84"	18 to 35	3000	Skid Steer	1250	570

With optional Valve Manifold add 120 lbs (55 kg)

PTO ROTO-RAKE

Model	Working Width	PTO Spline & RPM	Hp	TPH Mount Cat	Pounds	Kilograms
RR84PTO18G	84"	540	35 min.	1 & 2	1650	750



WARNING!

Exceeding the recommended specifications can result in damage to the equipment and will void all REIST Industries warranties.

The following references are used throughout this Operator's and Parts Manual:

Attachment, Implement	Refers to the ROTO-RAKE whether attached or separate from the prime mover
Prime Mover	The engine-driven machine to which this product is attached
Equipment	Refers to the Implement and or prime mover whether separate or connected
WARNING, DANGER, IMPORTANT	A notice that relates to the safe and efficient operation of the ROTO-RAKE or prime mover. Read and understand the reference before attaching or operating the ROTO-RAKE or the prime mover.

GENERAL SAFETY PRECAUTIONS

Careful operation is the best assurance against accidents. It is the owner's responsibility to make sure that all operators read and understand this manual and follow the recommendations, cautions and warnings before connecting to a prime mover and operating the equipment. The REIST ROTO-RAKE was designed for use to grade and level all types of soil including stone dust, gravel or similar products.

Familiarize yourself with all controls and know how to quickly stop the equipment and all rotating parts in the case of an emergency.

Never let an untrained person or a child operate equipment.

WARNING!

DO NOT MODIFY THE ROTO-RAKE OR PRIME MOVER

Modifications may weaken the integrity of the ROTO-RAKE and may impair the operation, safety, and performance of the product. When making repairs, only qualified technicians using the manufacturer's genuine parts, following authorized instructions, shall attempt the repair. Never modify any ROPS (Roll Over Protection Structure) or FOPS (Falling Object Protective Structure) equipment or other safety device or remove guarding. Any modifications must be sanctioned in writing by an authorized representative of the manufacturer.

WARNING!

MAINTAIN AND REPAIR EQUIPMENT SAFELY

- Do not wear loose clothing, or any accessories that can catch in moving parts
- If you have long hair, cover or secure it so that it does not become entangled in the equipment
- Work on a level surface in a well-lit area.
- Always lower raised equipment to the ground or securely support it to prevent unintentional movement
- Remove and retain the prime mover's ignition key
- Use the correct tool for the job at hand. Make sure they are in good condition for the task required
- Wear the protective equipment specified by the tool manufacturer
- Use care when working on hydraulic systems and understand how to check for and release trapped hydraulic pressure

GENERAL SAFETY PRECAUTIONS



WARNING!

STAY CLEAR OF ROTATING OBJECTS

Keep hands, feet and clothing away from power driven rotating parts.

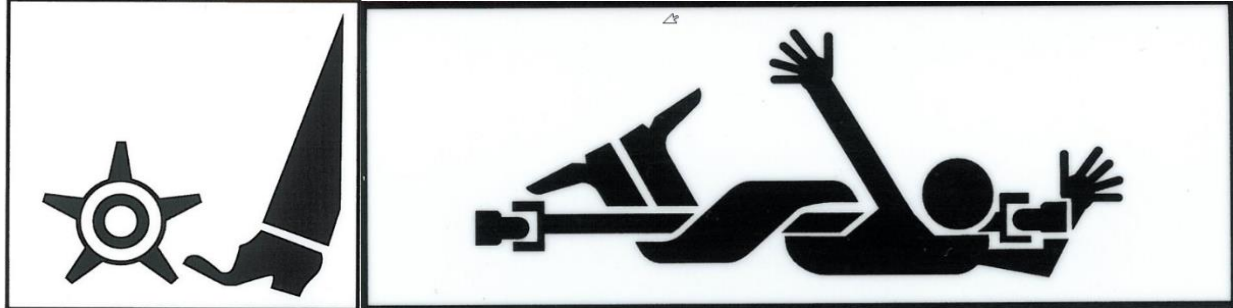

Never use your hands to clear if clogged. Never allow anyone to reach into the rotor housing. The rotor can crush and/or dismember. Keep everyone clear of the rotor until the prime mover engine is off and the hydraulic pressure has been relieved.



WARNING!

READ OPERATOR'S MANUAL BEFORE OPERATING

Do not operate equipment until you are completely trained by a qualified operator in how to use the controls, understand the machine's capabilities, dimensions, and all safety requirements. Refer to your operator's manual for these instructions.

- Do not operate an engine in confined or non-ventilated area
- Do not perform adjustments or repairs with the engine running
- Always lower raised equipment to the ground or securely support it to prevent unintentional movement
- Do not operate on excessive inclines or side slopes – know the limitations of the prime mover – be careful when turning on slopes as a rollover condition may exist
- Never carry passengers
- Keep bystanders away from the machine when in operation
- Be aware of pedestrians
- Know how to quickly stop the equipment and all rotating parts in the case of an emergency
- Stop the prime mover, lower implements and turn off the engine before dismounting
- Refer to the prime mover's Operator's Manual for additional information







OPERATION AND TRANSPORTATION ON PUBLIC ROADS AND AREAS

Always adhere to the local laws and regulations concerning traveling or operating on public roadways and areas. Clean all lights, reflectors and mirrors ensuring that all lighting is in working order before moving. Know the area! i.e. Elevations, steep side drop offs. Watch out for pedestrians and use caution when approaching pedestrians, hazardous objects (stones, etc.) may inadvertently be discharged. Do not engage or disengage the PTO while roading. Always be alert while transporting or operating the equipment. Select a safe ground speed when transporting from one area to another. When operating, or driving on roadways, travel in such a way that faster moving vehicles may pass you safely.

SAFETY DECALS

Contact REIST Industries if replacement safety signs are required.

DECAL PART NUMBERS

Item	Part Number	Description
	WD114	<u>Drive Line Decal</u>
	Serial	<u>Serial Number Decal</u>
	WD111	<u>WARNING Rotating Knives & Spikes</u>
	WD112	<u>Read Manual Decal</u>
	RD107	<u>REIST Decal</u>
	RD115	<u>Made in Canada Decal</u>
	WD116	<u>Flying Objects Decal</u>

MAINTENANCE

Refer to the General Safety Precautions, page 6 of this manual before performing any maintenance.

1. Always ensure the ROTO-RAKE is properly installed, the prime mover is positioned on a level surface with the park brake set and the ROTO-RAKE positioned on the ground
2. Shut-off the engine and remove and retain the ignition key
3. Chock the wheels to prevent movement and release residual hydraulic pressure
4. Grease hinge points every 50 hrs.
5. At the beginning of each season, ensure that all fasteners are properly torqued, all safety guards are in place and that operator's manual is reviewed and understood
6. At the end of season, perform all maintenance activities protect exposed hose ends and the PTO drive splines (if equipped). Always check for missing or damaged parts and repair as required

ADDITIONAL MAINTENANCE FOR THE PTO18G SERIES

1. Check oil level in sight glass. Use a Universal hydraulic oil if top is required
2. Change filter as instructed on next page
3. Grease PTO crosses if applicable daily (or 8 hours of operation) with EP2

PTO18G OIL FILTER MAINTENANCE

In-tank Filter Servicing



Check the filter service indicator.

- Check to see that the OEM specified service interval has been reached or that the service indicator shows that the filter is due for servicing.



Turn system off and release pressure.

- Ensure that the hydraulic system is turned off.
- Check that there is no pressure present.



Remove the housing cover.



Remove the used filter, gasket and spring, if applicable.

- Remove the filter as gently as possible.
- Avoid contaminant dropping into the clean side of the housing.
- Properly dispose of the cartridge, seal and spring.



Clean the filter mount, cap, inside of the housing and cover.

- Clean out any sediment from the inside of the filter housing.

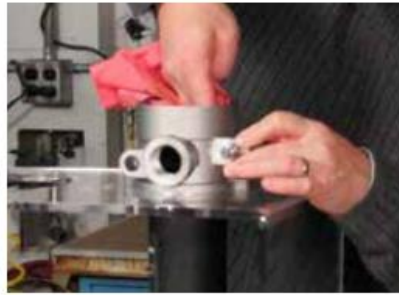

- Wipe away any sediment on the outside of the filter cover.



Inspect the new filter cartridge for damage.

- Check the new filter you will be installing for any shipping and handling damage.



Lubricate the filter gasket and cover seal.

- Lubricate the new filter cartridge O-ring and cover seal with clean system oil.



Install new filter and spring, if applicable.

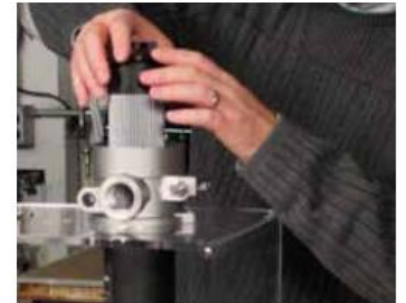

Reinstall the housing cover.

- Refit the cover following any instructions given.



Bleed the system and check for leaks.

STANDARD SETUP INSTRUCTIONS

Improper installation, operation, or maintenance of this equipment could result in serious injury or death. FOLLOW ALL SAFETY INSTRUCTIONS IN THIS MANUAL AND THE PRIME MOVER'S MANUAL(S).

Refer to the operator's manual(s) for your prime mover and follow the mounting instructions contained therein.



WARNING!

STAY CLEAR OF ROTATING OBJECTS

Keep hands, feet and clothing away from power driven rotating parts.

SKID-STEER HOOKUP INSTRUCTIONS

The standard ROTO-Rake has a universal Skid Steer mount. Attach Skid steer to Roto-Rake and attach the two Hydraulic hoses. Different makes of skid steers have different wiring configurations. You need the correct wiring harness.

OPERATION OF ROTO-RAKE

- Be sure the area is clear of all bystanders
- Refer to the prime mover starting instructions
- Lower ROTO-RAKE to ground, putting skid steer arms in float position.
- For leveling control, you want the weight on the wheels of the Roto-Rake
- Tip the bucket cylinders of the skid steer until tips of rotor are at desired depth.

PTO18G SETUP INSTRUCTIONS

PTO18G HOOKUP INSTRUCTIONS

The PTO ROTO-RAKE hitch has category one or two. Use the proper pin sizes when attaching the ROTO-RAKE to the prime mover. Do not attach the PTO driveline at this time.

- a. Always ensure that the PTO shaft is proper length! Make sure PTO shaft doesn't bottom out or come apart throughout the range of movement for the 3 PTH.
- b. Connect the ROTO-RAKE to the lower arms of the 3-point hitch. Be sure the 3-point hitch is set in the non-sway position (See prime mover manual for details)
- c. Measure the distance from the end of the prime mover PTO shaft to the end of the gear box shaft on the ROTO-RAKE
- d. Lay driveline on flat surface and measure the distance from one end to the other in the most collapsed position
- e. If distance from the end of the prime mover PTO shaft to the end of the gear box shaft on the ROTO-RAKE is greater than 9" more than the overall length of the collapsed driveline, the driveline may be too short. When the PTO shaft is at the longest position there should be a minimum of 3" overlap.
- f. Once the driveline is installed, connect the upper link
- g. When it is safe to do so, slowly lift the ROTO-RAKE thru the complete arc of the 3-point mount. Make sure driveline does not bottom out at anytime throughout the arc. Make sure the driveline shields are in place and do not separate

-Note a 540 rpm PTO drive has 6 splines or teeth and is 1 3/8 inch in diameter.

OPERATION OF PTO ROTO-RAKE

- Be sure the area is clear of all bystanders
- Refer to the prime mover starting instructions
- Always use proper pin and bushing sizes when attaching Roto-Rake to tractor.
- Stabilized 3 PTH arms to centre.
- Lower ROTO-RAKE to ground, putting 3 PTH lever to max. down position.
- Adjust top link until tips of rotor are at desired depth.

GROUND SPEED:

- Travel speed is governed by the condition of the surface being graded.
- The deeper the cut and harder the material the more power is required and the speed has to be adjusted according.

STANDARD FEATURES ASSEMBLY

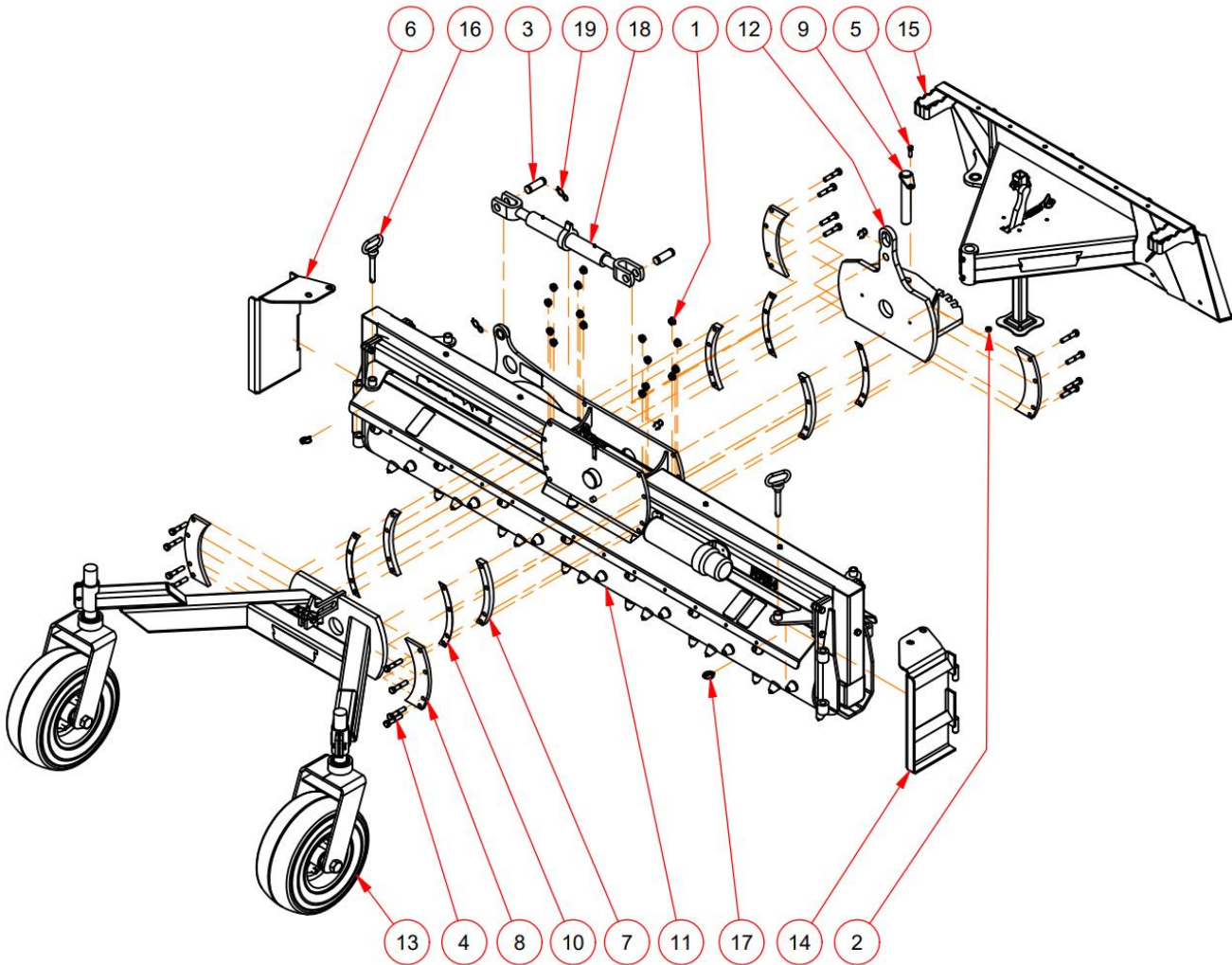

Parts List				Parts List			
ITEM	QTY	PART NUMBER	DESCRIPTION	ITEM	QTY	PART NUMBER	DESCRIPTION
1	16	12FSLN	Flange Nut	11	1	107220	Roto Rake 84
2	1	38FSLN	Flange Nut	12	1	107228	Knuckle
3	2	100x225	Pin	13	1	107237	Wheel Attachment - RR72, RR84, & RR96
4	16	12212	Hex Bolt	14	1	122412	Side Gate Left Assembly
5	1	38114	Hex Bolt	15	1	122783	15 Deg Base Swivel Frame Assembly
6	1	100183	Side Gate Assembly	16	2	384502	Draw Pin 58
7	4	103938	Spacer	17	2	385501	3/16 Lynch Pin
8	4	103939	Clamp	18	1	386501	Ratched Jack
9	1	103944	Pin	19	4	637856	Hair Pin
10	4	107166	Shim				

RR84 ROTO RAKE-ASSEMBLY

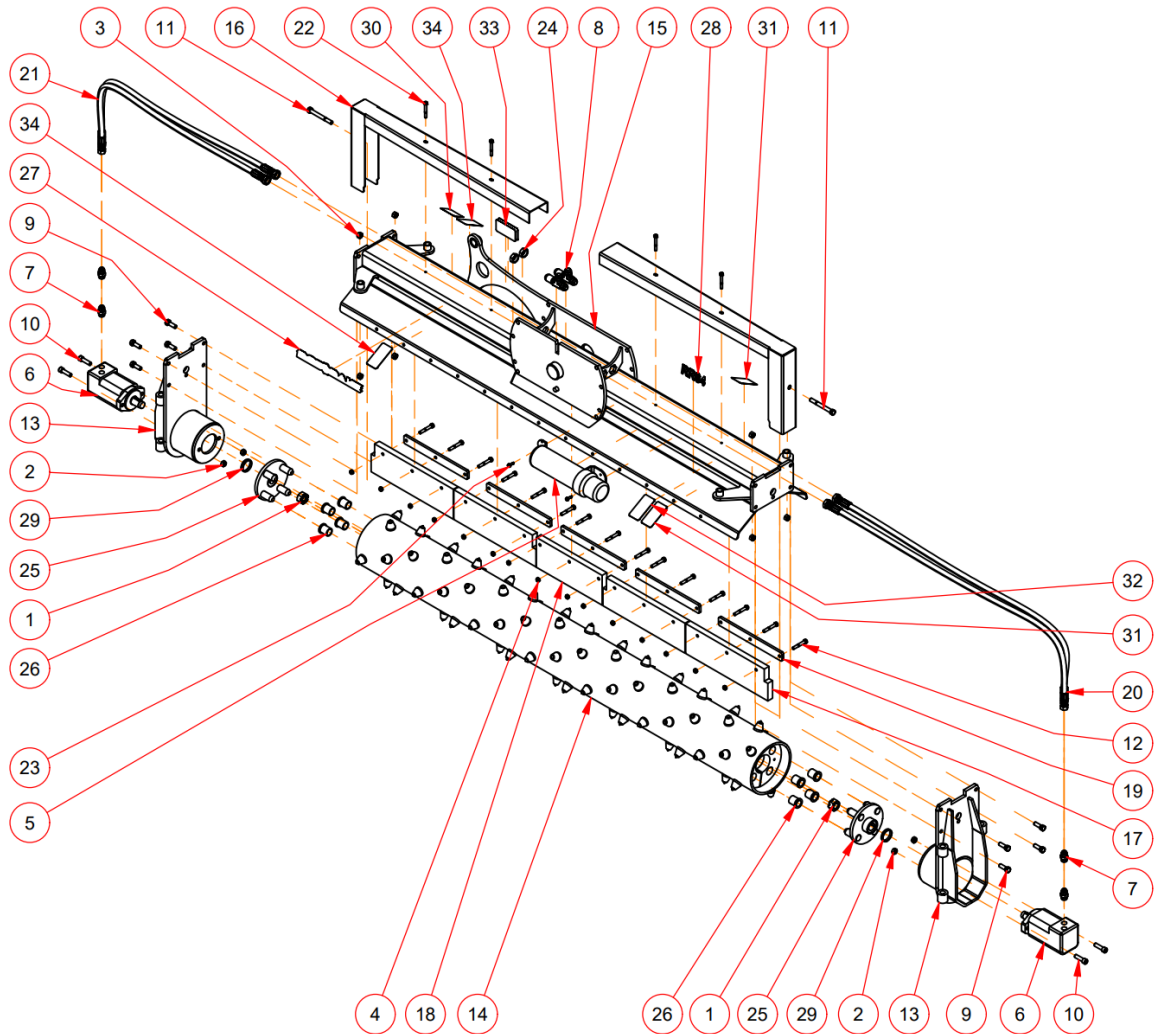

Parts List				Parts List			
ITEM	QTY	PART NUMBER	DESCRIPTION	ITEM	QTY	PART NUMBER	DESCRIPTION
1	2	1CNF	Slotted Hex Nut	20	2	114913	Hydraulic Hose H24508-08U610-08U612-61
2	4	12CLN	NC Lock Nut	21	2	114920	Hydraulic Hose H24508-08U610-08U612-49
3	8	12N	Hex Nut	22	4	516212	Hex Bolt
4	15	38CLN	NC Lock Nut	23	2	2167121	Self Drilling 14x1 Metal Screw
5	1	67.222.000	Manual Holder	24	2	HN 1 116 - 12 UN JAM	Hex Jam Nut 1-1/16 - 12 UN
6	2	104-4100-006	2000 series hyd motor 2 bolt	25	2	HRG04	Rotor Drive Adaptor Weldment
7	4	5315*10	Fitting	26	8	MF1-1620-24	Igus bushing
8	2	5726*12	JIC Bulkhead Run Tee	27	1	RD132	Roto-Rake Decal
9	8	12112	Hex Bolt	28	1	RD136	RR84 Decal
10	4	12134CSH	Socket Head	29	2	RVA-045	Oil Seal
11	2	12412	Hex Bolt	30	1	Serial	Serial # Plate
12	15	38212NC	BP NC Hex Bolt	31	2	WD111	Danger to Feet - Stay Clear of Front! Decal
13	2	100175	Hyd Motor Mount	32	1	WD112	WARNING - Read Manual Decal
14	1	107188	Rotor 84	33	2	WD115	WARNING Pinch Point Decal
15	1	107218	Roto Rake Frame Weldment 84	34	2	WD116	WARNING Flying Object Decal
16	2	107226	Hose Shield Side 84				
17	4	113075	Rubber				
18	1	113078	Rubber Center				
19	5	113079	Plate				

RR84 WHEEL ASSEMBLY

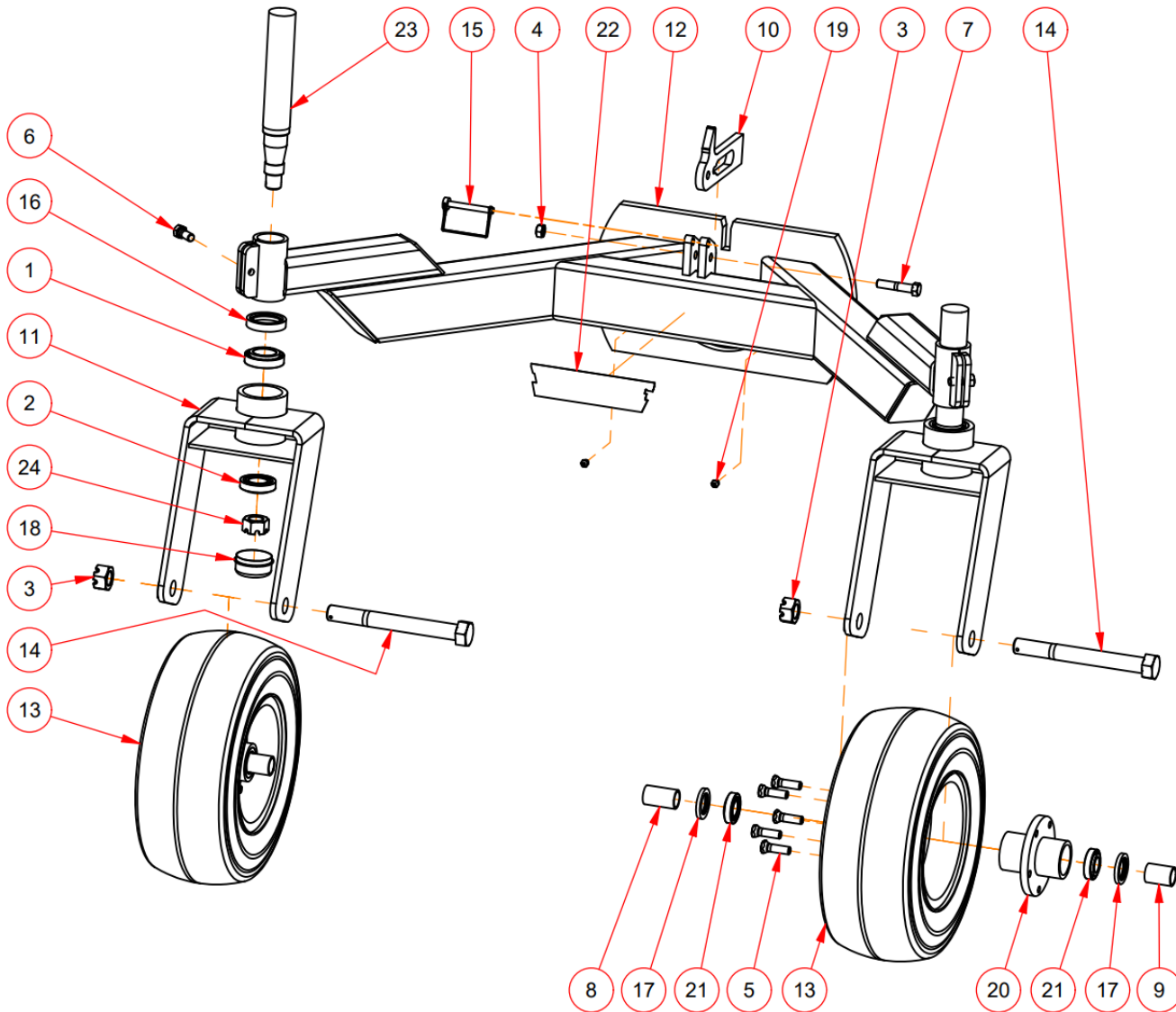

Parts List				Parts List			
ITEM	QTY	PART NUMBER	DESCRIPTION	ITEM	QTY	PART NUMBER	DESCRIPTION
1	2	1.5 x 2.5625 x 0.71 - LM29749 LM29710X	Tapered Roller Bearing	12	1	107235	Wheel Attachment Frame
2	2	1.25 x 2.328 x 0.625 - LM67045 LM67010	Tapered Roller Bearing	13	2	108110	Wheel 16.5x8 5 on 4.5
3	2	1CNF	Castle Hex Nut	14	2	117443	1-9NF BP Hex Bolt w 3/16 Hole
4	1	12CLN	NC Lock Nut	15	1	387113	Pin
5	10	500-20	Wheel bolt Bolt	16	2	CR17415	SEAL
6	2	12114	Hex Bolt	17	4	CR523696	Seal
7	1	12212	Hex Bolt	18	1	D4000	Dust Cap
8	2	107106	Spacer L	19	2	GF	1/8 NPT ST Zerk
9	2	107107	Spacer S	20	2	H010005450	Hub
10	1	107229	Locking Plate	21	4	L44643 L44610	Tapered Roller Bearing
11	2	107233	Swivel Wheel Weldment	22	1	RD106	Reist Decal
				23	2	S04000175-1200	Spindle
				24	2	SJ-114	Slotted Hex Nut

STANDARD 15 DEGREE SWIVEL FRAME ASSEMBLY

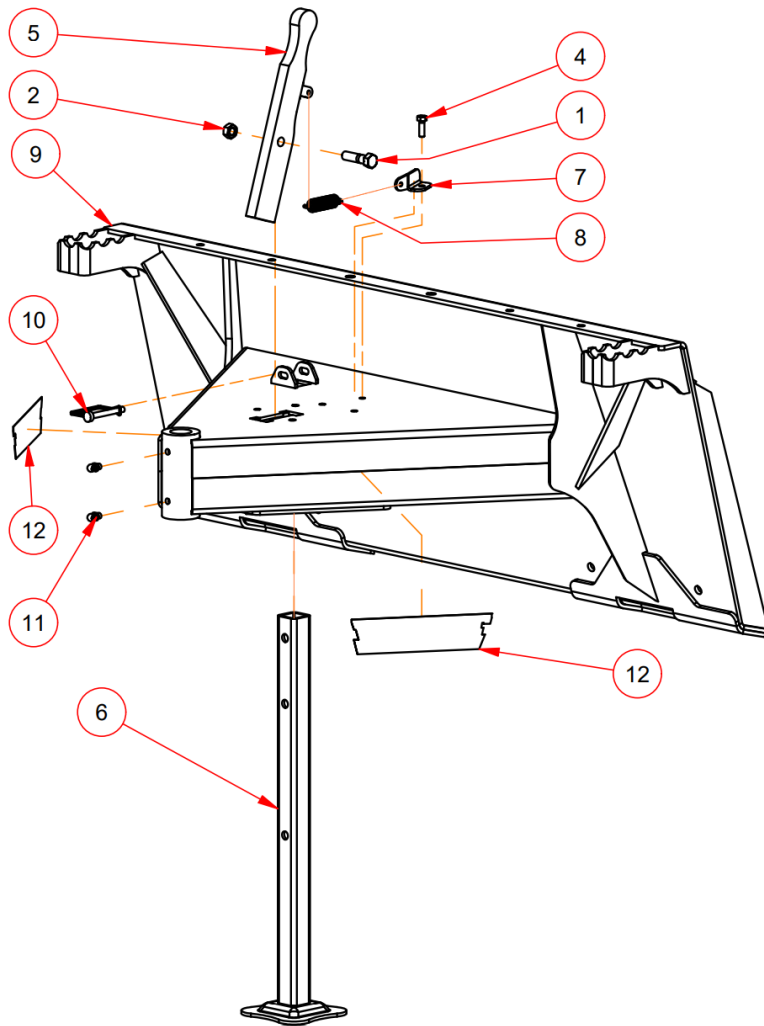

Parts List			
ITEM	QTY	PART NUMBER	DESCRIPTION
1	1	12*2	Hex Bolt
2	1	12CLN	NC Lock Nut
3	1	516N	Hex Nut
4	1	5161	Hex Bolt
5	1	100185	Roto Rake Swivel Lock Lever
6	1	100186	Roto Rake Swivel Frame Stand
7	1	110666	Spring Bracket
8	1	117250	Extension Spring E1905-267-0635
9	1	121597	15 Deg Swivel Frame Weldment
10	1	387109	Lock Pin
11	2	GF	1/8 NPT 90deg Zerk
12	2	RD106	Reist Decal

RR84 - 15 DEGREE BASE SWIVEL FRAME ASSEMBLY

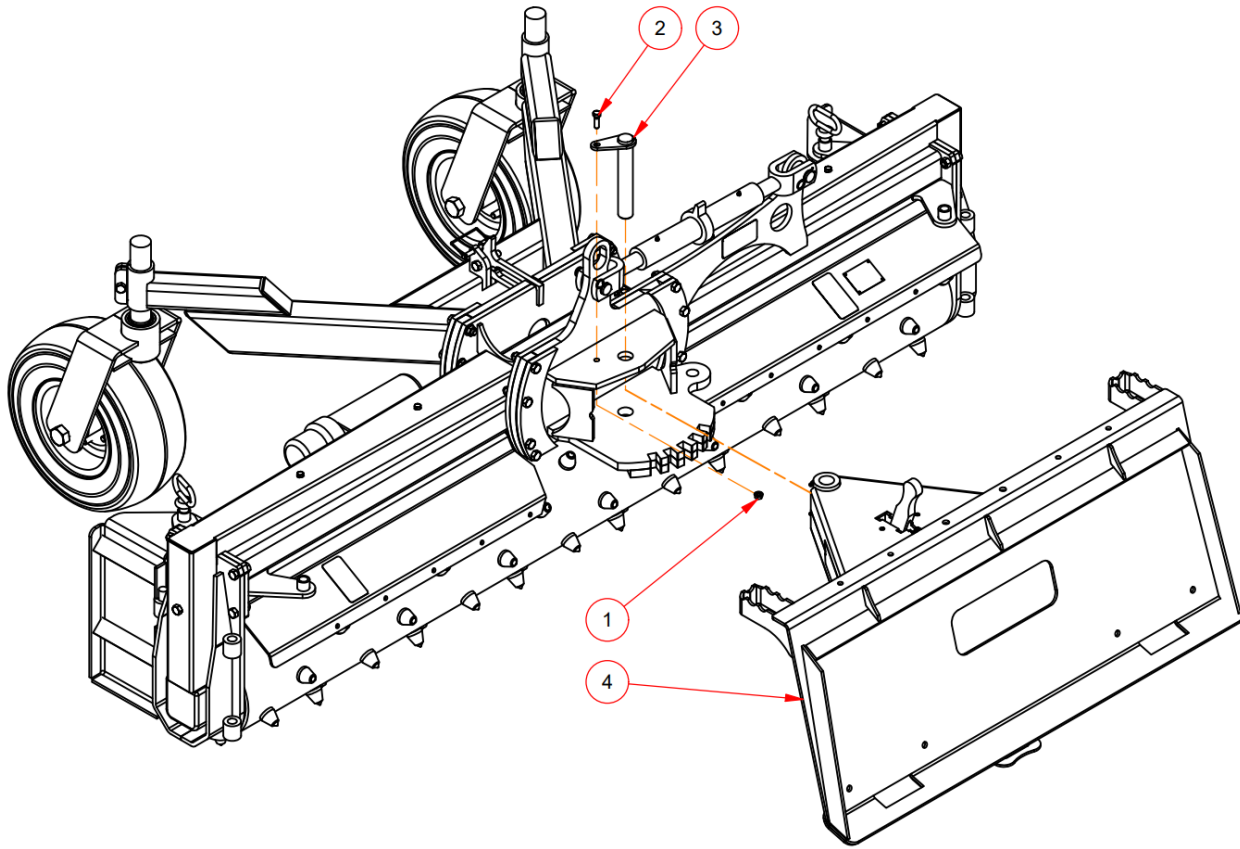

Parts List			
ITEM	QTY	PART NUMBER	DESCRIPTION
1	1	38FSLN	Flange Nut
2	1	38114	Hex Bolt
3	1	103944	Pin
4	1	122783	15 Deg Base Swivel Frame Assembly

OPTIONAL ON THE FLY HYDRAULIC VALVE BLOCK

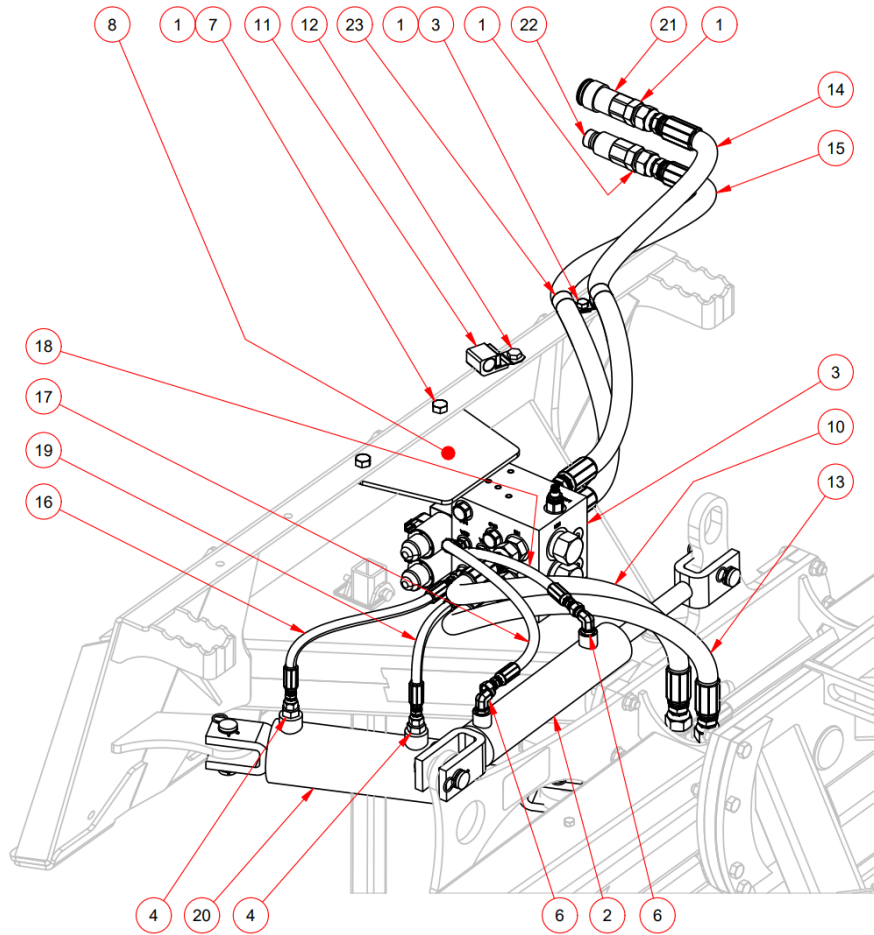

Parts List				Parts List			
ITEM	QTY	PART NUMBER	DESCRIPTION	ITEM	QTY	PART NUMBER	DESCRIPTION
1	3	12FSLN	Flange Nut	14	1	123598	Hydraulic Hose H145512-12U612-12U672-34
2	1	20FEM08-NW	Ditching Cylinder	15	1	123600	Hydraulic Hose H145512-12U612-12U672-34
3	1	381	Hex Bolt	16	1	123604	Hydraulic Hose H24504-04U606-04U666-16
4	2	5315*6*8	Fitting	17	1	123606	Hydraulic Hose H24504-04U606-04U666-25
5	6	5315*12	Fitting	18	1	123608	Hydraulic Hose H24504-04U606-04U666-17
6	2	5515*6	90 Elbow Fitting	19	1	123610	Hydraulic Hose H24504-04U606-04U666-14
7	2	12114	Hex Bolt	20	1	CL3006-S	3x6 Clevis Angling Cylinder
8	1	121898	Guard Plate	21	1	FEM501-12F0	Female Flat Face Coupler
9	1	123247	ROTORAKE F Valve Block	22	1	FEM502-12FO	Male Flat Face Coupler
10	1	123427	Hydraulic Hose H145512-12U612-12U672-26	23	2	HK1713	1 "HoseClamp
11	1	123584	RR Clamp				
12	1	123585	RR Clamp Bolt				
13	1	123596	Hydraulic Hose H145512-12U612-12U672-30				

OPTIONAL HYDRAULIC VALVE BLOCK DETAILS

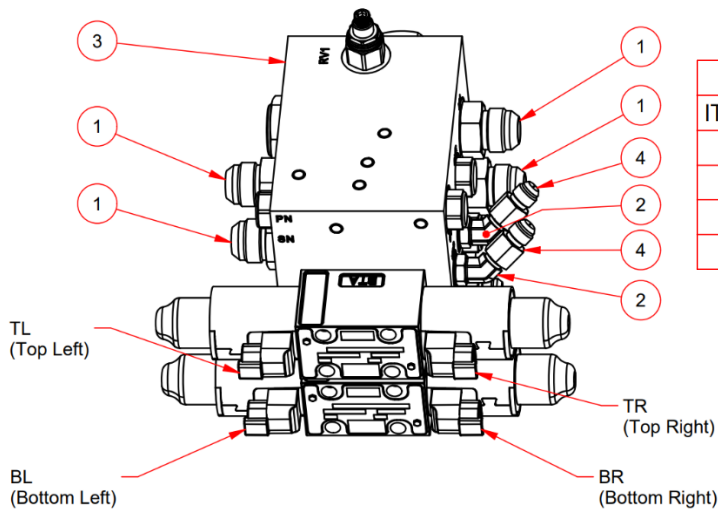

Parts List			
ITEM	QTY	PART NUMBER	DESCRIPTION
1	4	5315*12	Fitting
2	2	5365*6	45 Elbow JIC/Straight
3	1	123247	ROTORAKE F Valve Block
4	2	RES5100	0606-032 Restrictor Fitting

Solenoid operates Port		RotoRake Reaction
Top Right	V2A	Tilt Clock Wise
Top Left	V2B	Tilt Counter Clock Wise
Bottom Left	V1B	Angle Right
Bottom Right	V1A	Angle Left

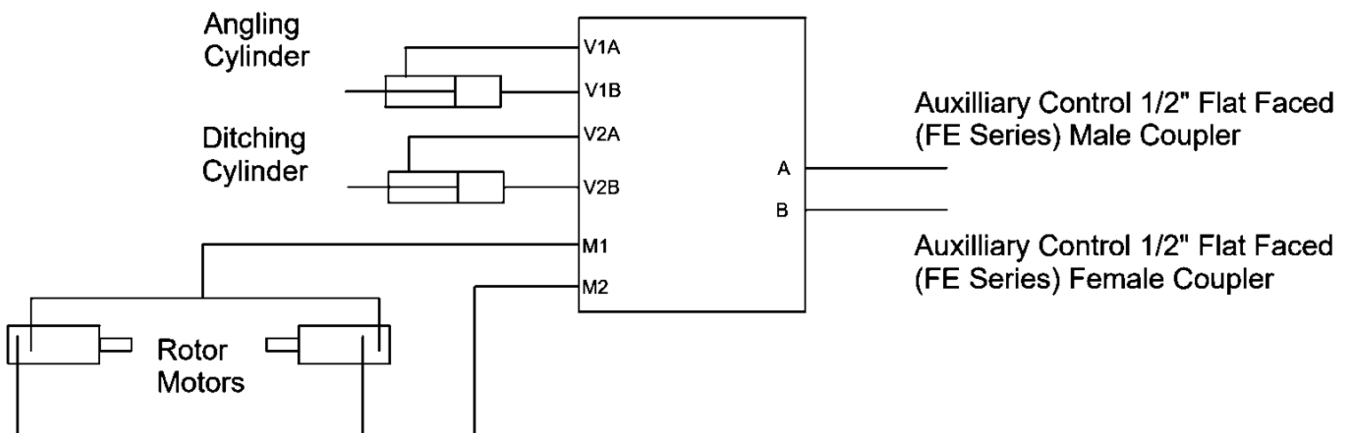

OPTIONAL VALVE BLOCK WIRING HARNESSSES

Use wiring harnesses starting with part number EWKV#### to connect the Valve Manifold to the prime mover.

Harness ID	Number of Pins	MFG	PLUG LOCATION ON VALVE			
			Top Left - CCW	Top Right - CW	Bottom Left - Angle Right	Bottom Right - Angle Left
EWKV14BO	14	BOBCAT	C2B	C2A	C1B	C1A
	14	KUBOTA	C1B	C1A	C2B	C2A
	14	NEW HOLLAND	C1A	C1B	C2A	C2B
EWKV14CAT	14	CAT	C2B	C2A	C1B	C1A
	14	GEHL	C1B	C1A	C2B	C2A
		JCB				
MUSTANG						
VOLVO						
	YANMAR					
	14	TAKEUCHI	C2A	C2B	C1B	C1A
EWKV14CNH	14	CASE	C2B	C2A	C1B	C1A
EWKV14WN	14	WACKER	C2B	C2A	C1B	C1A
EWKV14JD	14	JOHN DEERE	C2B	C2A	C1B	C1A
EWKV8CAT	8	ASV	C2B	C2A	C1B	C1A
		CAT				
		TEREX				
EWKV7BO	7	BOBCAT	C2B	C2A	C1B	C1A
RRMTSV01	N/A	Manual Toggle	C2B	C2A	C1B	C1A

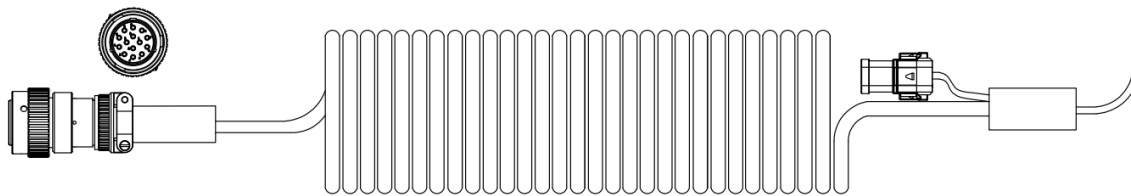
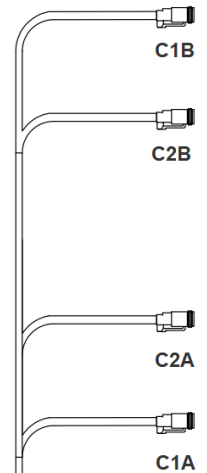

Showing 14 Pin Plug

OPTIONAL DIVERTOR VALVE

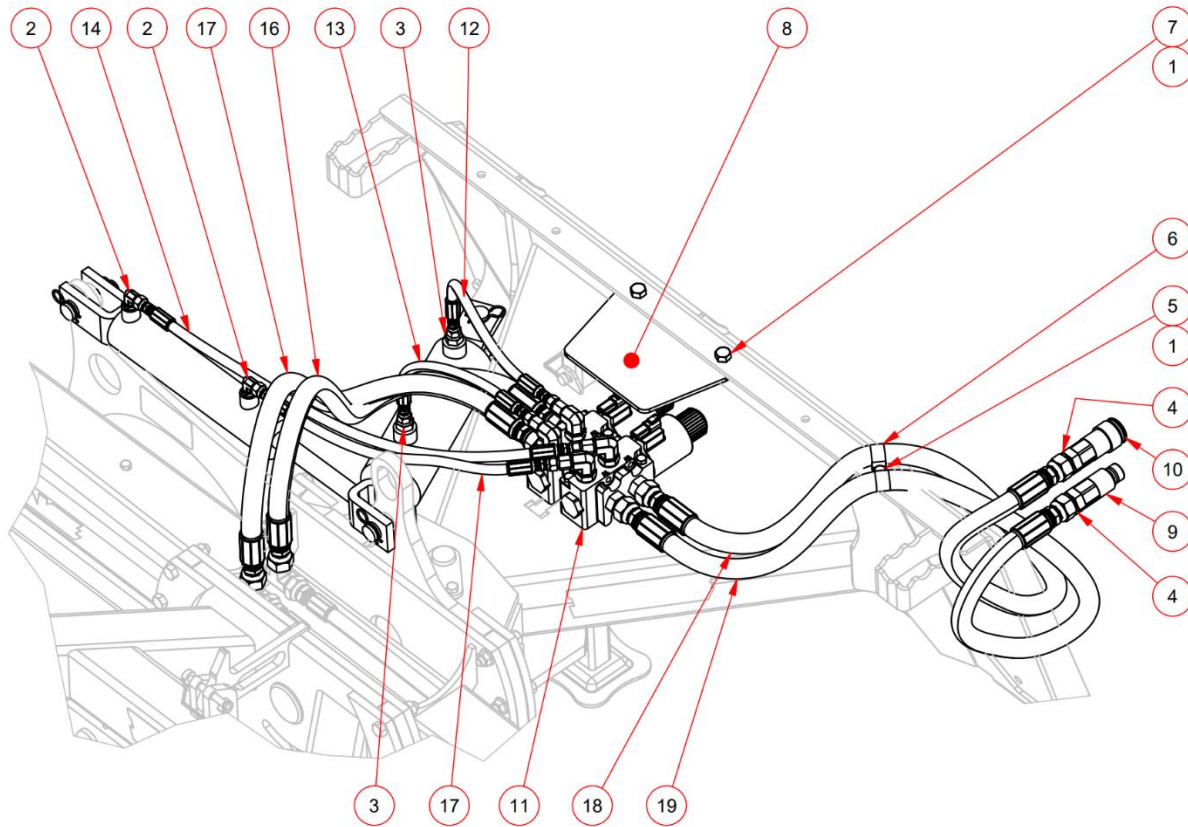

Parts List				Parts List			
ITEM	ITEM QTY	PART NUMBER	DESCRIPTION	ITEM	ITEM QTY	PART NUMBER	DESCRIPTION
1	2	12FSLN	Flange Nut	13	1	124663	Hydraulic Hose H24504-04U606-04U666-15
2	2	5515*6	90 Elbow Fitting	14	1	124665	Hydraulic Hose H24505-04U606-04U666-28
3	2	5315*6*8	Fitting	15	1	124671	Hydraulic Hose H24505-04U606-04U666-20
4	2	5315*12	Fitting	16	1	124674	Hydraulic Hose H145512-12U612-12U672-28
5	1	381	Hex Bolt	17	1	124677	Hydraulic Hose H145512-12U612-12U672-29
6	2	HK1713	1 "HoseClamp	18	1	124680	Hydraulic Hose H145512-12U612-12U672-32
7	2	12114	Hex Bolt	19	1	124682	Hydraulic Hose H145512-12U612-12U672-32
8	1	121898	Guard Plate				
9	1	FEM502-12FO	Male Flat Face Coupler				
10	1	FEM501-12FO	Female Flat Face Coupler				
11	1	DFE140-6	Walvoil 6 Way Solenoid Control Sectional Diverter Valve				
12	1	124657	Hydraulic Hose H24504-04U606-04U666-18				

OPTIONAL DIVERTOR VALVE DETAILS & SCHEMATIC

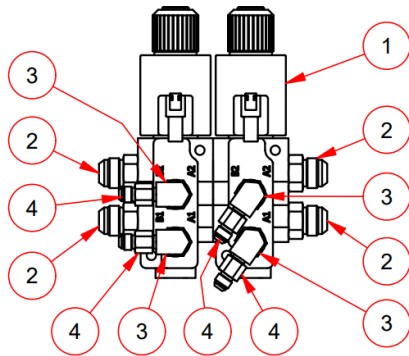

Parts List			
ITEM	QTY	PART NUMBER	DESCRIPTION
1	2	DFE 140-6	Walvoil 6 Way Valve
2	4	5315*12*10	Fitting
3	4	5515*6*10	90 Elbow Fitting
4	4	RES5100	0606-032 Restrictor Fitting

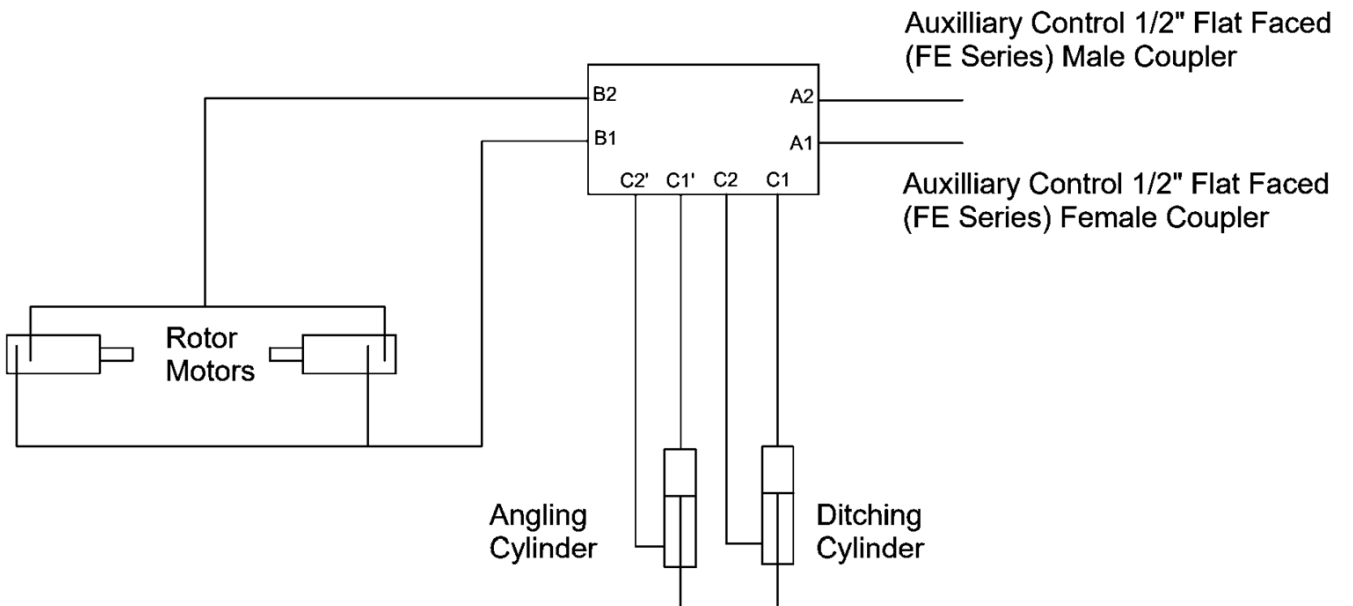

WIRING HARNESSES

Use wiring harnesses starting with part number EWKD#### to connect the Walvoil 6 Way Solenoid Control Sectional Divertor Valve to the prime mover.

Divertor Wiring Harnesses	
Part Number	Description
EWKD14BO	Bobcat Skidsteers 14 Pin Wiring Kit (Deutsch Plug)
EWKD14CAT	Caterpillar & Gehl Skidsteers 14 Pin Wiring Kit (Deutsch Plug)
EWKD14CNH	Case & New Holland Skidsteers 14 Pin Wiring Kit (Deutsch Plug)
EWKD14JCB	JCB & Volvo Skidsteers 14 Pin Wiring Kit (Deutsch Plug)
EWKD14JD	John Deere 244J Loader & John Deere Skidsteers 14 Pin Wiring Kit (Deutsch Plug)
EWKD14KU	Kubota & Wacker Neuson Skidsteers 14 Pin Wiring Kit Deutsch Plug)
EWKD14TA	Takeuchi Skidsteers 14 Pin Wiring Kit (Deutsch Plug)
EWKD7BO	Bobcat Skidsteers 7 Pin Wiring Kit (Deutsch Plug)

Use the wired remote manual toggle switch (part number RRMTS01) to operate the divertor valve from the prime mover.

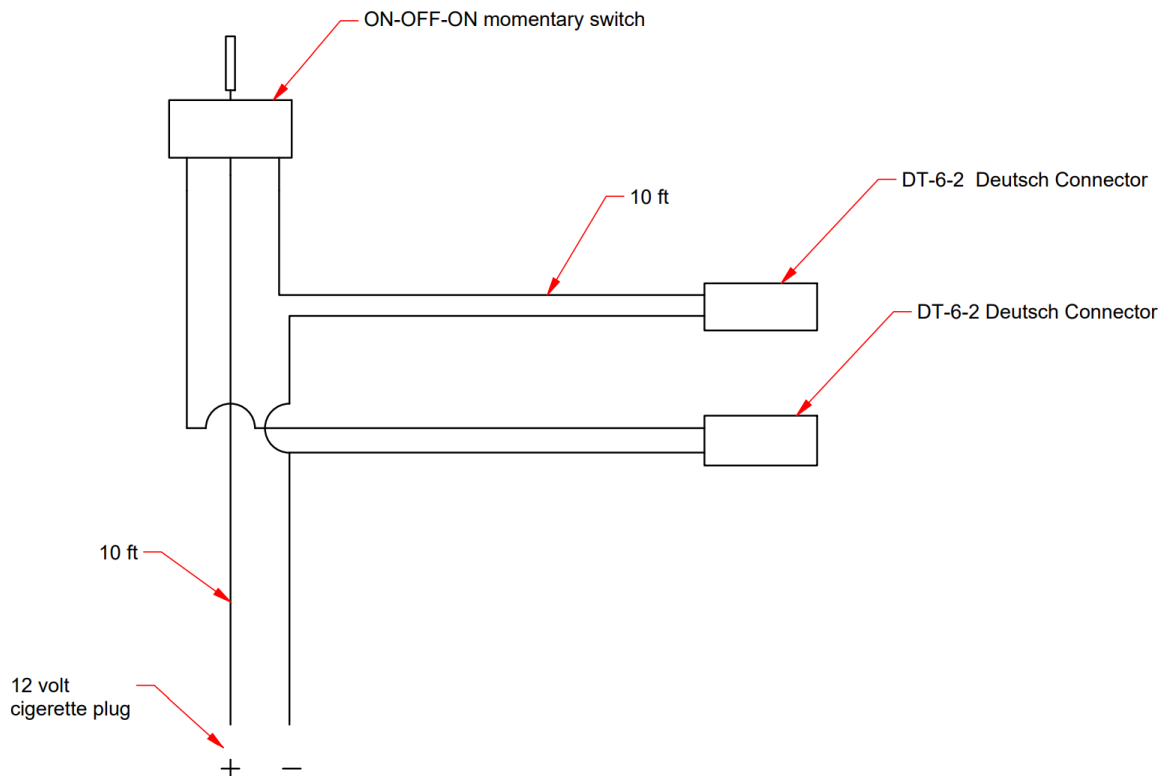

RR84PTO18G - ASSEMBLY

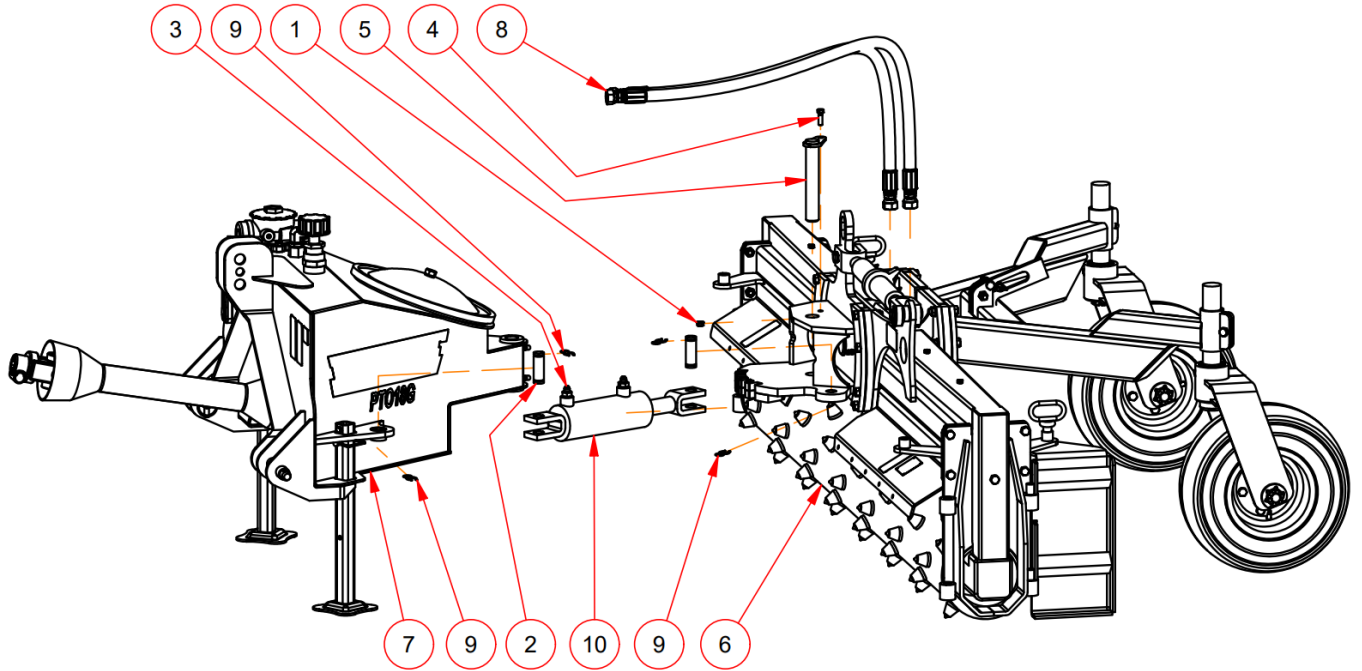

Parts List			
ITEM	QTY	PART NUMBER	DESCRIPTION
1	1	38FSLN	Flange Nut
2	2	100x225	Pin - 1.00 x 2.375" (Active Length - 3.00" OA)
3	2	5315*6*8	Fitting
4	1	38114	Hex Bolt
5	1	103944	Pin
6	1	107220	Roto Rake 84
7	1	111649	Base Swivel Frame Oil Tank
8	2	114958	Hydraulic Hose-H14512-12U612-12U612-48
9	4	637856	Hair Pin
10	1	CL3006-S	3x6 Clevis Cylinder

PTO18G – EXPLODED VIEW

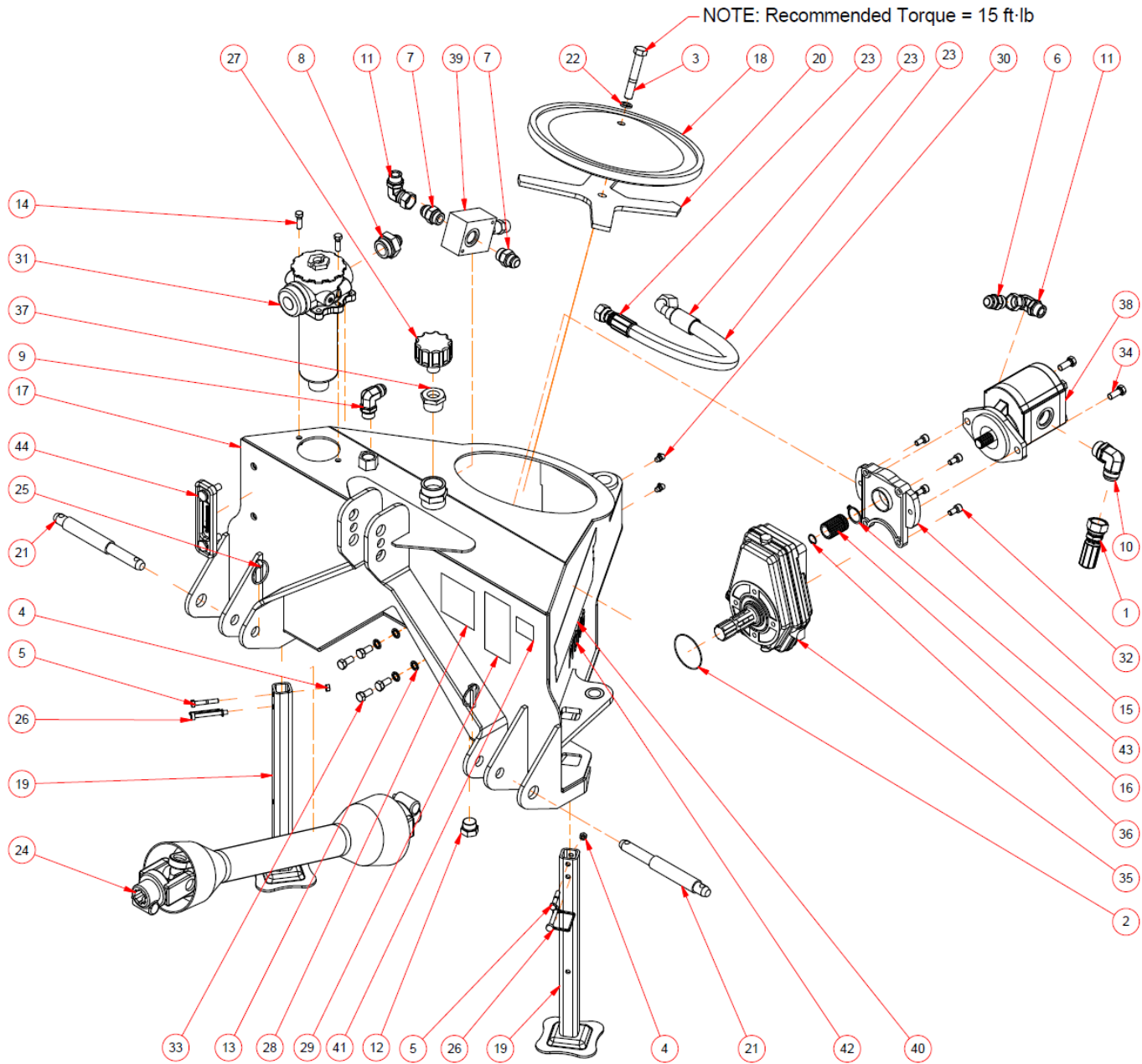

PTO18G – PARTS LIST

Parts List			
ITEM	QTY	PART NUMBER	DESCRIPTION
1	1	12U616	Female JIC Swivel Hose End
2	1	041	O Ring
3	1	58*4	Hex Bolt
4	2	516N	Hex Nut
5	2	5162	Hex Bolt
6	1	5302*12	JIC Nipple
7	2	5315*12	Fitting
8	1	5315*12*20	Fitting
9	1	5515*12	90 Elbow Fitting
10	1	5515*16	90 Elbow Fitting
11	2	6809-1212	SAE JIC Elbow
12	1	7237*12	Oring Male Plug (-12)
13	4	9900-04	Bonded Seal 14BSPP (12mm)
14	2	38114	Hex Bolt
15	1	110485	Flange MB30-S5
16	1	110486-	Splined Coupling MB30-04
17	1	111650	Base Swivel Frame Oil Tank Weldment
18	1	111684	End Cover 5065
19	2	111686	Stand
20	1	111688	Spider Weldment
21	2	111689	Cat 1 & 2 Pin
22	1	112163	Plastic Washer 58
23	1	114954	Hydraulic Hose H14512-12U672-12U612-26-1/2
24	1	225332	T40-061_1-38x6 Slide Collar QD 2 Ends
25	2	385507	7/16 Lynch Pin
26	2	387109	Lock Pin
27	1	ABS40N12	3/4" Breather Cap
28	1	DD100	Drive Line Decal
29	1	DW103	Read Manual Decal
30	2	GF	1/8 NPT 90deg Zerk
31	1	K040813	Tank Filter_Element P171840
32	4	M10X20SH	Socket Head Cap Screw - Metric
33	4	M12x1.75x25	Metric Bolt
34	2	M12x1.75x30	Metric Bolt
35	1	MBA30-M6-3.5	Increaser Gearbox-MBA30-M6-3.5(1:3.5)
36	1	N5000-81	internal retaining ring
37	1	PFG-00214-0	NPT Reducer
38	1	PLP30.34SR	Pump Right Hand Rotation
39	1	RCL12-3000	Relief Valve
40	2	RD105	Reist Decal
41	1	RD115	Made In Canada Decal
42	2	RD137	PTO18G Decal
43	1	SH-131	External Snap Ring
44	1	SLT-1214	Level Gauge

OPTIONAL SIDE CUTTERS - RRSCK

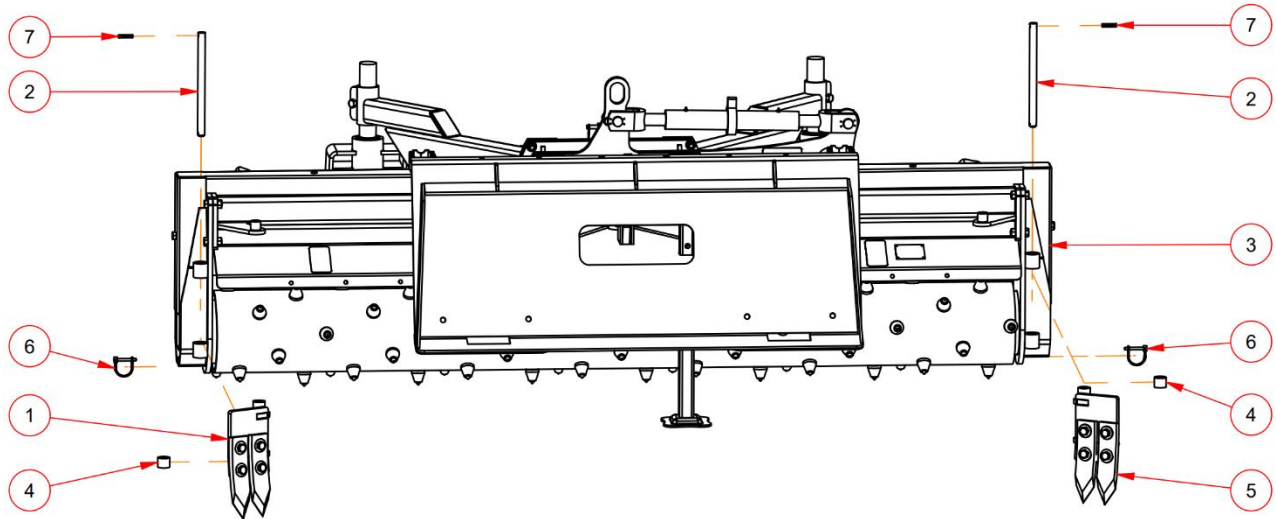

Parts List			
ITEM	QTY	PART NUMBER	DESCRIPTION
1	1	100192	Plow Attachment
2	2	100193	Pin
3	1	107220	Roto Rake 84
4	2	120359	Spacer Bushing
5	1	123311	Plow Attachment Left
6	2	387104	Snapper Pin 1/4 x 1-3/8
7	2	516112RP	Roll Pin

Note: Item #4 120359-Spacer Bushing can be placed above or below the Plow Attachments depending on the depth of cut desired.
Side gates and optional side cutters can be exchanged depending on direction of travel.

OPTIONAL PLOW ATTACHMENT ASSEMBLY

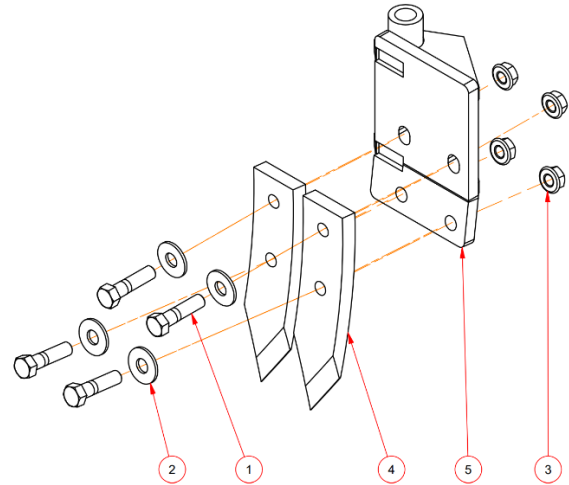
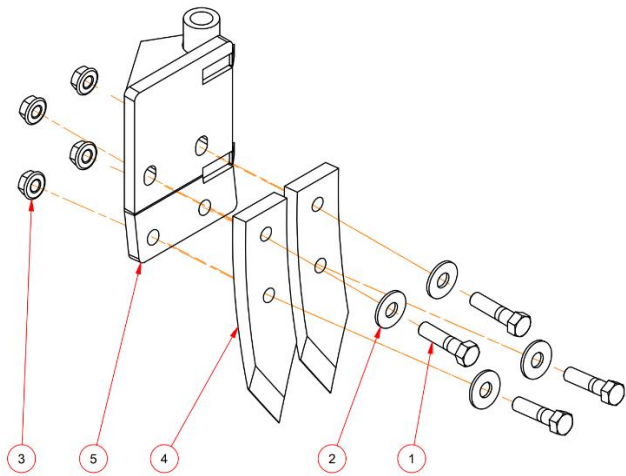

Parts List			
ITEM	QTY	PART NUMBER	DESCRIPTION
1	4	12*2	Hex Bolt
2	4	12F	Flat Washer
3	4	12FSLN	Flange Nut
4	2	1009	5/8x2 Spike Tooth
5	1	104898	Plow Weldment

Parts List			
ITEM	QTY	PART NUMBER	DESCRIPTION
1	4	12*2	Hex Bolt
2	4	12F	Flat Washer
3	4	12FSLN	Flange Nut
4	2	1009	5/8x2 Spike Tooth
5	1	123310	Plow Weldment Left

WARRANTY INFORMATION

All new REIST machinery is warranted to be free from defects in material or workmanship, which may cause failure under normal usage and service when used for the purpose intended for a period of 12 months. This warranty applies only to a new REIST product, there being no warranty of any nature in respect to new products that have been modified or altered, repaired, neglected, or used in any way, which, in the opinion of REIST adversely affects its performance.

In the event of failure of a part or parts, and upon inspection, REIST is satisfied that failure is due to defective material or workmanship within 12 calendar months from the date of delivery to an end user, such defective part or parts will be repaired or replaced by REIST Industries Inc. It is the responsibility of the buyer, at his expense, to transport the machine or equipment to the manufacturer service shop or to an authorized service depot or, alternatively, to reimburse REIST for any travel or transportation expense involved in fulfilling this warranty.

When requested by REIST, part or parts shall be returned for inspection, transportation prepaid, to a place designated by REIST. IN NO EVENT SHALL THE BUYER BE ENTITLED TO RECOVER FOR INCIDENTAL OR CONSEQUENTIAL DAMAGES, INCLUDING, BUT NOT LIMITED TO, LOSS OF PRODUCT, INCONVENIENCE, RENTAL OR REPLACEMENT EQUIPMENT, LOSS OF PROFIT, OR OTHER COMMERCIAL LOSS.

This warranty becomes void and null if the equipment is modified, breaks down as the result of an accident, is not operated according to manufacturer's recommendations, damaged by negligence or if maintenance has not been carried out as specified.

THIS WARRANTY IS NOT TRANSFERABLE

REIST Industries Inc.
100 Union Street
Elmira, Ontario, Canada
N3B 3L7